

JE 6-250 D11 FT40

Electric - Qmax 340 m³/h - 5666 l/min (1500 USgpm) - Hmax 18 m (59 ft)

Code on request



Product Data

Suction port
Flanged - DN150 DI 1882 TL (to be welded)

Delivery port
Flanged - DN150 DI 1882 TL (to be welded)

Qmax
340 m³/h - 5666 l/min (1500 USgpm)

Hmax
18 m (59 ft)

Solids handling
76 mm (3")

Motor power
11 kW - 15 HP

Motor brand
Electro Adda E3G

Weight
280 kg (617 lb)

Indicative picture of the product

Close-coupled self-priming centrifugal pump with electric motor

Characteristics

The J series self-priming centrifugal pumps are used in applications where a rapid priming capacity is required from demanding suction heights combined with the ability to transfer and manage polluted fluids, dirty and abrasives with suspended large diameter solids. The system is based on an inspectable pump casing which also acts as a water tank allowing a first quick priming without auxiliary systems, simplifying management of the system and reducing the time for maintenance. Within the physically permitted suction height limits, J pumps are a more comfortable and reliable solution than submersible pumps and vertical submersed impeller pumps.

Benefits

- 1) Rapid self-priming**
Without foot valve up to a height of 7.5 m (24.5 ft)
- 2) High resistance**
To abrasive liquids which are turbid and sandy
- 3) Semi-open impeller**
High thickness casting impact resistant
- 4) Wear plate/plates**
Easily replaceable cast iron wear plate/plates
- 5) Easy maintenance**
Removable front cover for direct access to the impeller

Applications

Industry:

clean, dirty, sandy, muddy, neutral, alkaline, acidic liquids; low viscous petroleum products, solvents even if dirty; milk of lime, caustic soda; washing, cooling, recirculation, smoke scrubbing.

Treatment:

pumping polluted corrosive wastewater containing sand, mud or solids in suspension; dosing neutralizing liquids; pumping out settled sludge.

Naval:

loading and unloading; bilge pumping; washing, fire-fighting, stripping, sanitary duty and circulation.

Agriculture:

surface irrigation; liquid manure oxygenation; transfer and spraying liquid manure or fertilizers; distribution of liquid animal feed; transfer of wine must; washing.

Varisco S.r.l. has certified its Quality, Environment and Safety Management System in accordance with the requirements of the international standard ISO 9001-14001-45001, recognized by the Lloyd Register.

Specification is subject to change without prior notice. Please check with your Varisco representative for the latest specifications.
Document release date: May 30th 2024

www.variscopumps.com

JE 6-250 D11 FT40



PERFORMANCE CURVES

Test according to **UNI EN ISO 9906 standard - level 2B**

Installed power: **11 kW - 15 HP (1.450 rpm)**

Test liquid: **clean water, density 1.000 kg/m³**

Spherical solids handling: **D.76 mm (3")**

Noise Curve

dB(A)=max noise level at 1 m

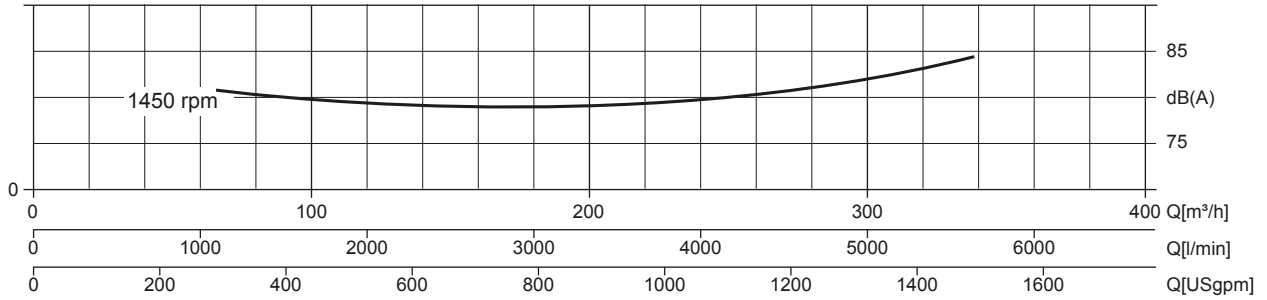

Speed Curve

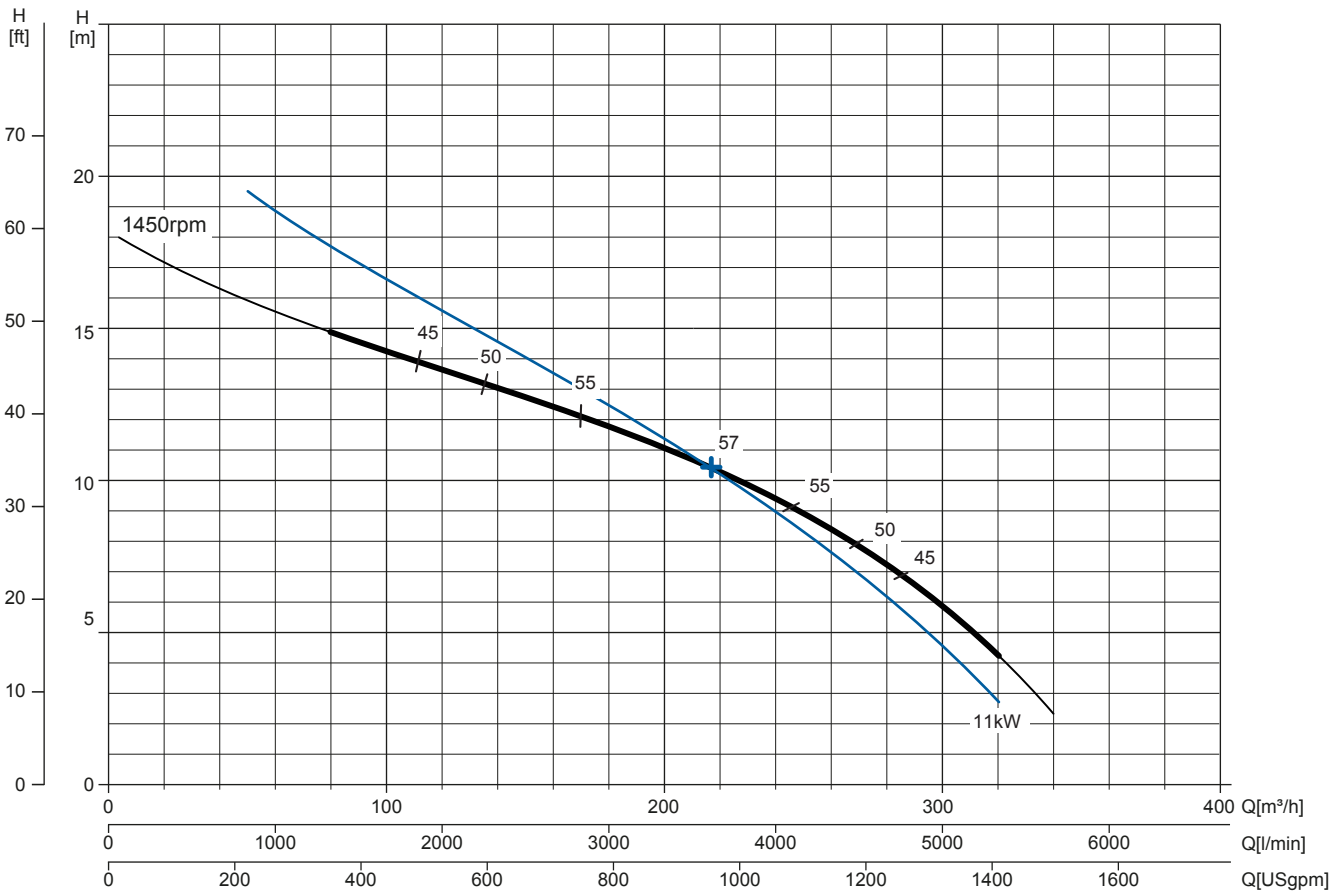

NPSHr Curve

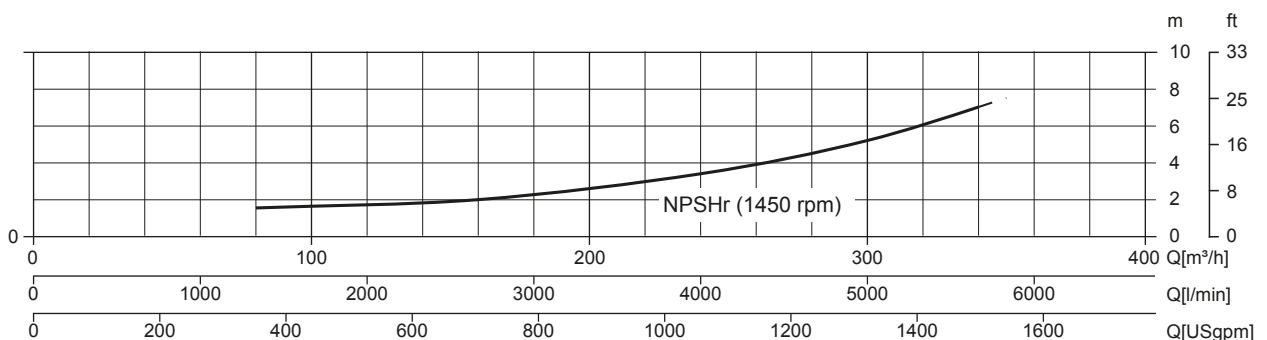

JE 6-250 D11 FT40



TECHNICAL DATA

Pump

Pump model	JE 6-250 D11 FT40
Qmax [1.450 rpm]	340 m ³ /h - 5666 l/min (1500 USgpm)
Hmax [1.450 rpm]	18 m (59 ft)
Suction port	Flanged - DN150 DI 1882 TL (to be welded)
Delivery port	Flanged - DN150 DI 1882 TL (to be welded)
Impeller type	Semi open, 2 vanes
Solids handling	76 mm (3")
Casing	EN 1561 EN-GJL-200 hardened cast iron
Impeller	EN 1563 EN-GJS-400 hardened cast iron
Wear plate	EN 1561 EN-GJL-200 hardened cast iron
Non-return valve	check-valve, NBR
Shaft	39NiCrMo3 EN 10083 carbon steel
Mechanical seal	Silicon carbide / Silicon carbide
Elastomers	NBR
Lubrication	Grease
Bearing bracket	EN 1561 EN-GJL-200 cast iron, with grease lubricated ball bearings for life

Hardness of treated components: casing - 350 HB, impeller - 380 HB, wear plates - 270 HB

Motor

Mains supply (Three-phase)	380 VD/660 VY ± 5%	400 VD/690 VY ± 10%	415 VD/720 VY ± 5%
Frequency (Nominal speed)	50 Hz ± 2%/ 1.450 rpm		
Absorbed current	19,1/11 A		
Starting Current Is/In	7.9		
Efficiency (100%)	91,4% (IE3)		
Model	Electro Adda E3G		
Standards	IEC 60034-1		
Construction	Cast iron, TEFC		
Mounting arrangement	IM 2001 B35		
No. poles	4		
Rated power	11 kW - 15 HP		
Degree of protection	IP55		
Markings	CE		
Insulation class/Temperature	F/80°K		
Duty type	Continuous - S1		
Temperature sensors	N/A		

Arrangement

Dimensions	1211/1251 x 475 x 620 mm (47,6/49.3 x 19 x 24)
Coating	Polyurethane enamel, average thickness of 100 µm
Color	RAL 5010 blue (standard)
Features	Close-coupling bell housing with double ball bearing
Height connection	0,45 m (1,5 ft)

Optionals

Flanged ports DN150 PN16 EN1092-2 Type B	code 10042352
Flanged ports 6" ANSI B16.1 Class 125 R.F.	code 10045100
Automatic mechanical seal greaser	code 10008316
Integrated VSD motor inverter	Available on request

Weight

Net weight	280 kg (617 lb)
------------	-----------------

JE 6-250 D11 FT40

DIMENSIONS

mm [in]

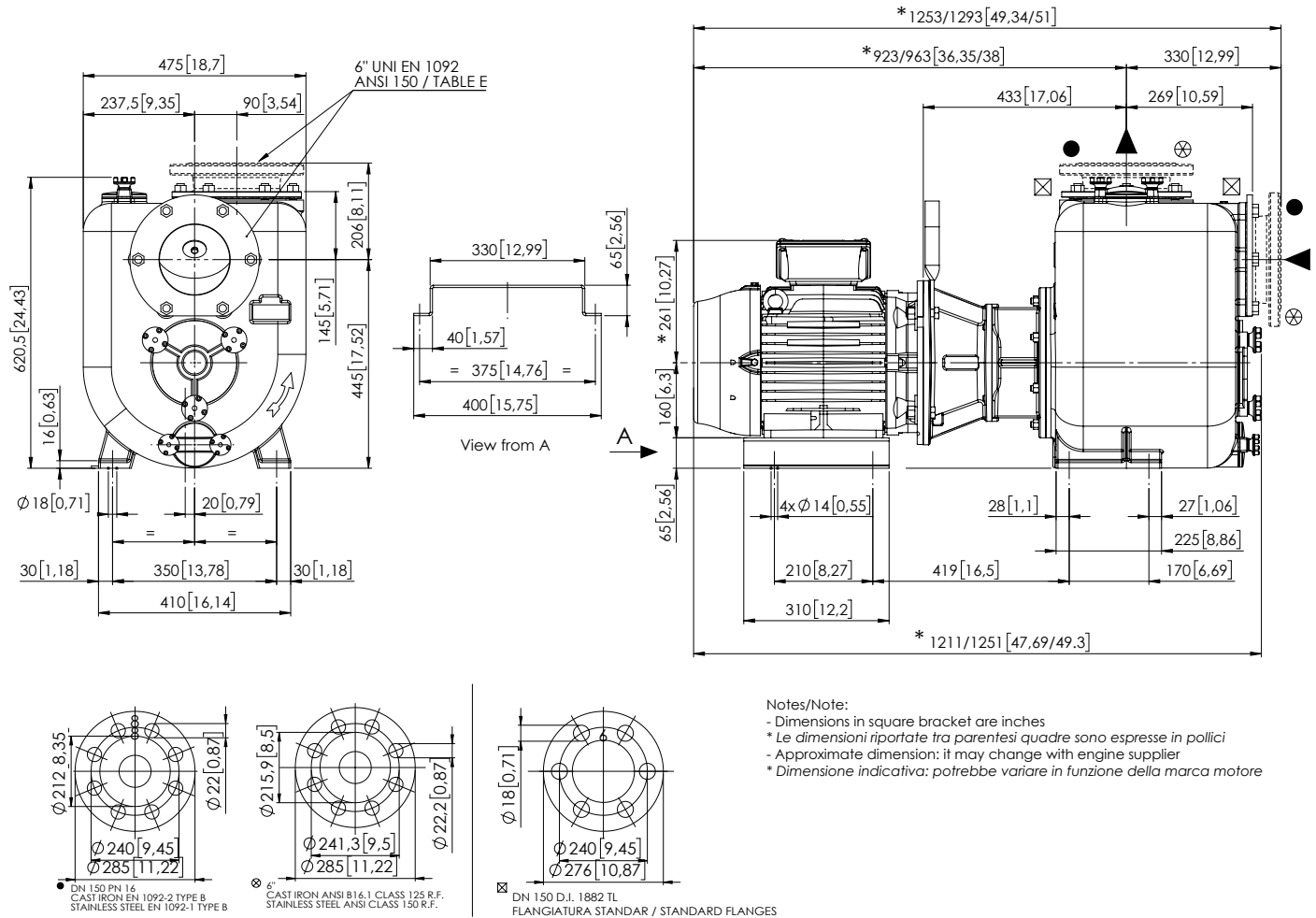

PACKAGING DIMENSIONS

Dimensions

JE 6-250 D11 FT40 (L x W x H mm)

1200 x 1000 x 950 mm

Gross weight (pump + packing)

315 kg (695 lb)

